

Product selected: SHP - TD 150W

Product Attributes

Item description	SHP - TD 150W
Bulb shape	Linear
Bulb finish / Light colour	Clear
Nominal wattage (W)	150
Nominal Voltage (V)	100
Cap	Rx7s-24
Maximum Lamp length L [mm]	135.4
Diameter D [mm]	25
Colour temperature (K)	1900
Ordering Code	0020711

Product Image



Product line drawing (image)

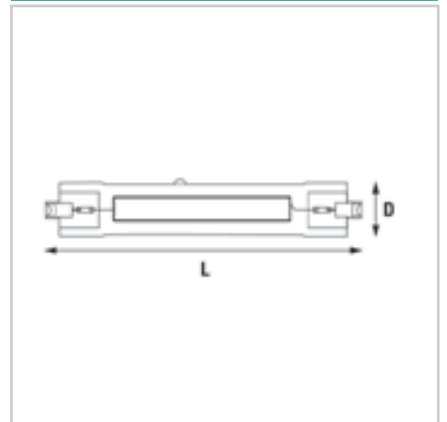

Run up characteristics (image)

High Pressure Sodium

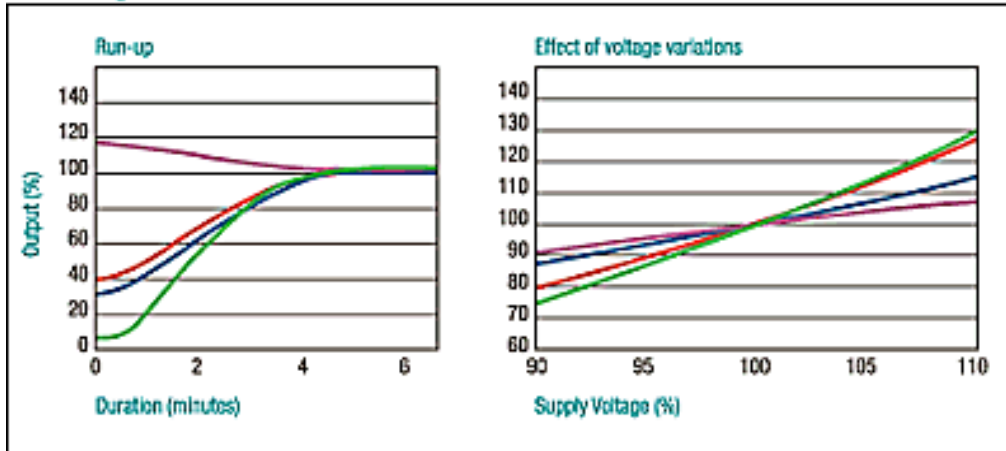

Re-start time when hot

Twinarc, SBY: immediate re-start

Standard, Super & MF: up to 1 minute

- Lamp Voltage
- Lamp Current
- Lamp Power
- Luminous Flux

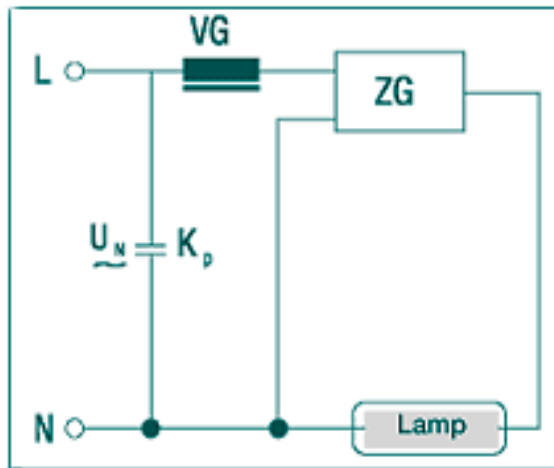
Circuit diagram (image)



- L Live conductor L₁, L₂, L₃
- N Neutral conductor
- U_n power supply voltage 230V~
(400V~ for HSI-T 2000V)
- VG ballast
- K_p lead capacitor
- ZG start-up system
- K_z start-up capacitor
- ST stray field transformer
- CWA constant wattage autotransformer